



Tip Redi-Rak Kit
PACE PART NUMBER 6021-0008
Installation Instructions
MANUAL NUMBER 5050-0385 REV. B

The PACE Tip Redi-Rak may be installed in any of the following configurations.

- 1. Free Standing** - The Tip Redi-Rak may be used as a free standing unit and placed in any location adjacent to the PACE power source.
- 2. Tip & Tool Stand Installation** - The Tip Redi-Rak can be installed in the sponge well (sponge removed) of any Tip & Tool Stand.
- 3. Power Source Chassis Mounting** - The Tip Redi-Rak be attached to the top of any PACE SensaTemp MBT, PRC or ST 50 system chassis.

Tip & Tool Stand Installation

The Tip Redi-Rak can be installed in the sponge well of any Tip & Tool Stand. To install the Tip Redi-Rak in your Tip & Tool Stand, perform the following procedure.

Remove any installed Sponge from the sponge well.

1. Insert the Tip Redi-Rak into the sponge well as shown.
2. Apply downward pressure to the Tip Redi-Rak to seat in the sponge well.

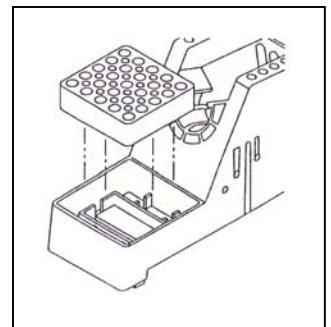

Power Source Chassis Mounting

To attach the Tip Redi-Rak to your MBT, PRC or ST 50 power source chassis, perform the following procedure.

1. Place the Tip Redi-Rak in the desired position on top of the power source chassis. Select 2 large holes in the Tip Redi-Rak that are located over or near a mounting slot on the chassis. The 2 selected large holes should be spaced apart and in alignment with each other front to back (refer to illustration).
2. Insert the 2 enclosed mounting screws down into the 2 selected holes in the Tip Redi-Rak. Push the end of each screw through the bottom of the Tip Redi-Rak and seat the screw head at the bottom of the hole.
3. Install the 2 enclosed hex nuts onto the end of each screw. Do not allow the screw ends to extend through the hex nuts. An engagement of 2-3 threads is sufficient.
4. Slide the hex nuts into the selected mounting slot from the rear of the system. Refer to illustration.
5. Slide the Tip Redi-Rak forward into the desired position.
6. Tighten the 2 screws to secure the Tip Redi-Rak in position.

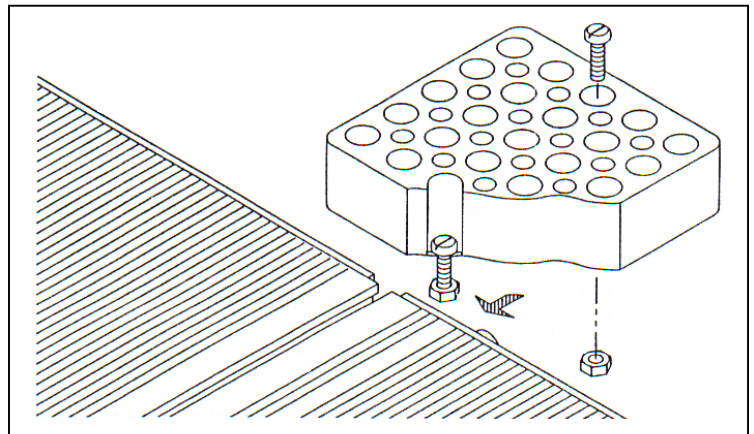

PACE Incorporated
9030 Junction Drive
Annapolis Junction,
MD 20701
Tel: (301) 490-9860
Fax: (301) 498-3252

PACE Europe Limited
13 Tanners Drive
Blakelands
Milton Keynes
Tel: (44) 1908-277666
Fax: (44) 1908-277777